

## Press-Fit Solder-Tags

The solder-tags are stamped from strip material and tinned afterwards. A stamped-in "nose" ensures exact positioning into the plastic and good pull-out strength. The wrapping area is slightly slimmer to avoid wire slipping off. Stamped holes are provided to connect external leads.

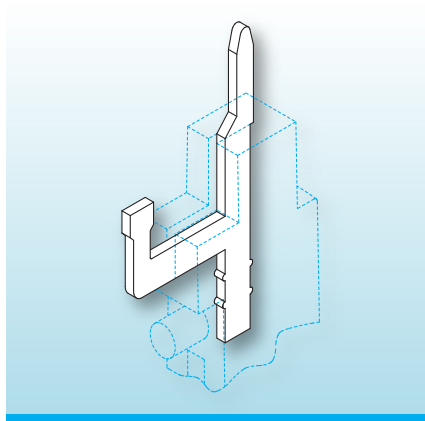

Special solder-tags can be produced to customers specifications, however, a minimum quantity of 250.000 pieces applies. Special materials and alternative finishes are available on request, dimensions in mm/*inch*.

When ordering please quote type and order-code.

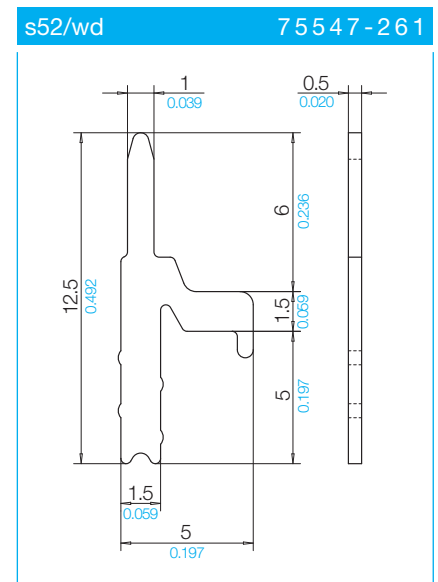
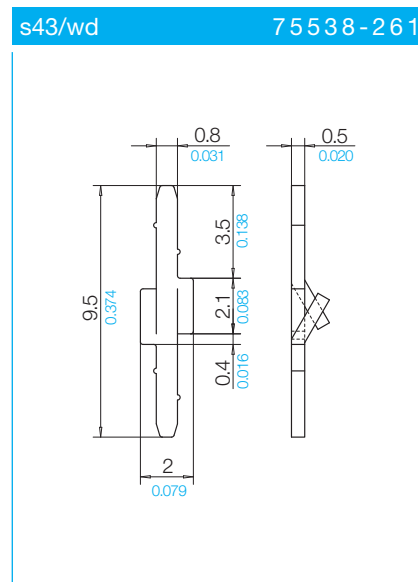
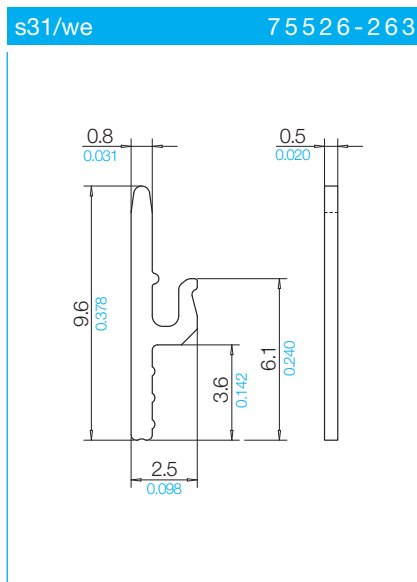

© 11/2020 by NORWE GmbH

Warranties:  
refer to Terms and Conditions of Sale



Valid version of  
data sheet online

QR Online-Version

**NORWE GmbH**

Postfach 13 56  
51691 Bergneustadt  
Paulstraße 5, Pernze  
51702 Bergneustadt  
Deutschland

Telefon +49 (0) 27 63-807-0  
Telefax +49 (0) 27 63-807-77  
E-mail [verkauf@norwe.de](mailto:verkauf@norwe.de)  
Internet [www.norwe.de](http://www.norwe.de)  
[www.norwe.eu](http://www.norwe.eu)

**NORWE Inc.**

P.O. Box 25 11  
North Canton, OH 44720-0511  
United States of America  
Telefon +1-330 497-8113  
Telefax +1-330 305-0592  
E-mail [usa@norwe.com](mailto:usa@norwe.com)  
Internet [www.norwe.com](http://www.norwe.com)