

Stamped components

The stamped components can be used in the traditional way for pinning electric and electronic components. They may also provide technical solutions in other areas. The information on the following pages should point you into the right direction.

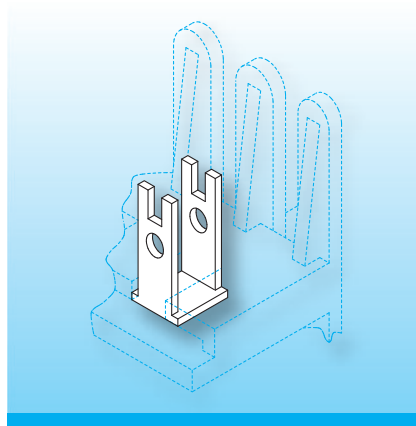

Specials can be produced to customers specifications and requirements, however, the minimum order-quantity is for 250.000 pieces. Special materials and alternative finishes on request, dimensions in mm/inch.

When ordering please quote type and order-code.

k2/wb 72000-257

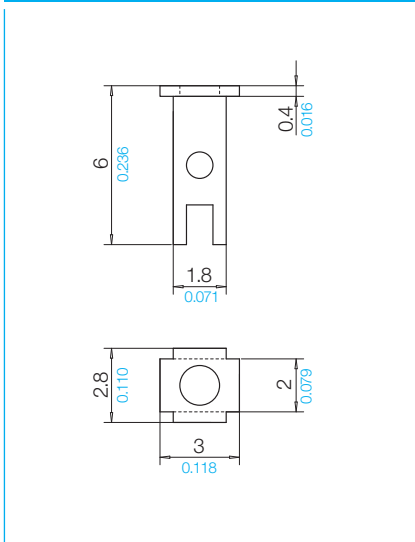

k3/wb 72020-257

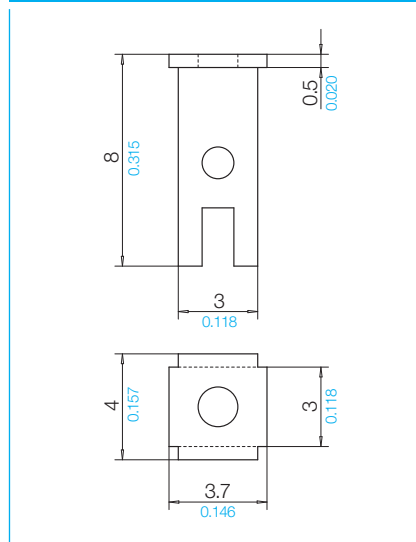

wg/wd 75170-261

