

EE-SMD-Coilformers (LDS)

The coilformers are made in gfr, cross-linked Polyamide PA66, CRE/35/8LDS2. LDS-structured surfaces 6–8 µm copper, 3–4 µm nickel coating and 0.1 µm gold finish. Maximum solder temperature 400°C, 3 sec. Special designs on request, dimensions in mm/inch.

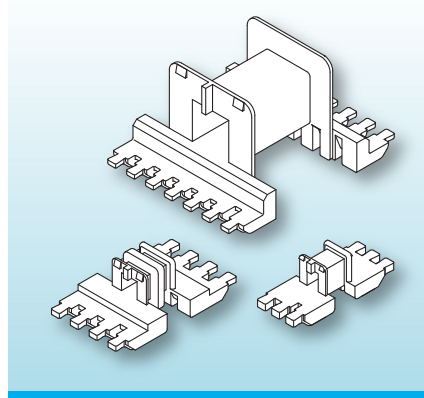

The SMD3-coilformers – like the existing SMD2-coilformers – feature separate winding on and soldering sides, compatible accessories and allow automatic processing. The new SMD-generation additionally impresses by optimal coplanarity, lower weight and excellent solder properties.

Type	Order-Code	Accessories
Coilformer: EE 5-SMD3/1k/6LD/CRE/35/8LDS2	N0070-117 on request	Pick and Place Cap P-EE 5
Coilformer: EE 5-SMD3/2k/6LD/CRE/35/8LDS2	N0076-117 on request	
LDS-Surface: lds-v1/ob	76400-381	

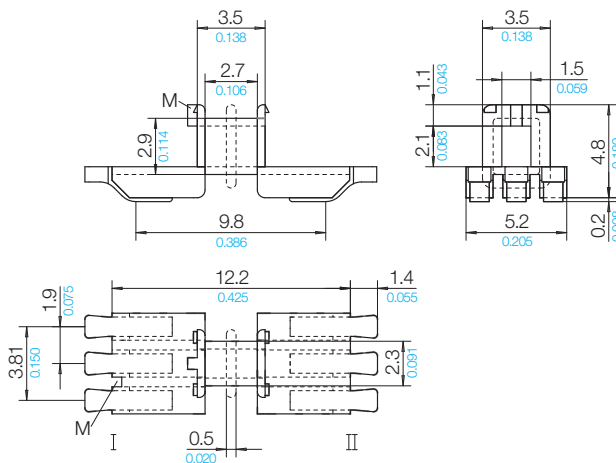

Connecting Surface

Contact side

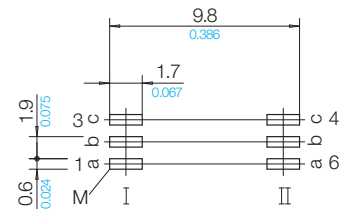

15 B 0 K

© 09/2018 by NORWE GmbH

Warranties:
refer to Terms and Conditions of Sale

NORWE GmbH

Postfach 13 56
51691 Bergneustadt
Paulstraße 5, Pernze
51702 Bergneustadt
Deutschland
Telefon +49 (0) 27 63-807-0
Telefax +49 (0) 27 63-807-77
E-mail verkauf@norwe.de
Internet www.norwe.de
www.norwe.eu

NORWE Inc.

P.O. Box 25 11
North Canton, OH 44720-0511
United States of America
Telefon +1-330 497-8113
Telefax +1-330 305-0592
E-mail usa@norwe.com
Internet www.norwe.com



Valid version of
data sheet online

QR Online-Version