

EI,UI Coilformers Horizontal

The coilformers are made in gfr Polyamide PA66 of type p6g (RTI long-range temperature +125°C). Pin material is tin bronze, tinned or brass, tinned for tags. Maximum solder temperature 350°C, 2sec. Special materials – e.g. irradiated cross-linked – and designs on request, dimensions in mm/inch.

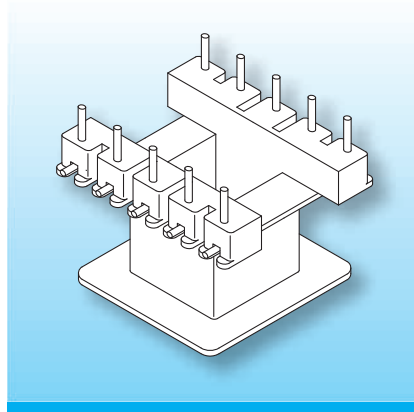

Due to their designs with different connection systems (press-fit pins, bent over pins, solder-tags, etc.) the coilformer-versions allow radial as well as axial binding on of the wires, matching your individual fields of application.

We are about to draw up a catalogue of this extensive series step by step – you will find the latest survey of available components on our homepage. For special designs and dimensions as well as available accessories please contact our technical specialists.

Type	Order-Code	Accessories
Coilformer: EJ 30-12/1k/4-8/5.0-ii/p6g Solder-pin: h811/ua	N0460-024 on request 73497-212	on request

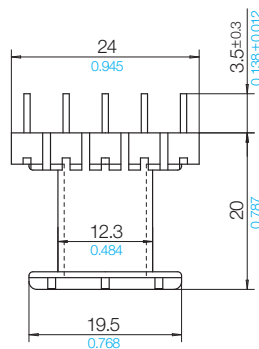
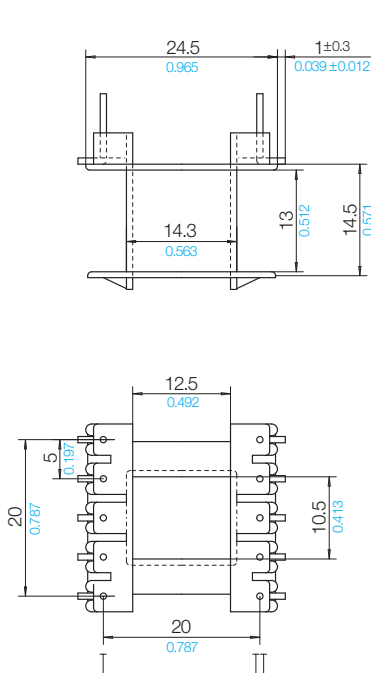

Grid
View tag-side

