

## EI, UI Coilformers

The coilformers are made in Polyamide PA66 gfr, UL 94 HB, temperature for longterm use at +130 °C. The material used is tin bronze, tinned (solder-pins) or brass, tinned (solder-tags). Maximum solder temperature 350 °C, 2 sec. (Special materials and designs on request, dimensions in mm/inch).

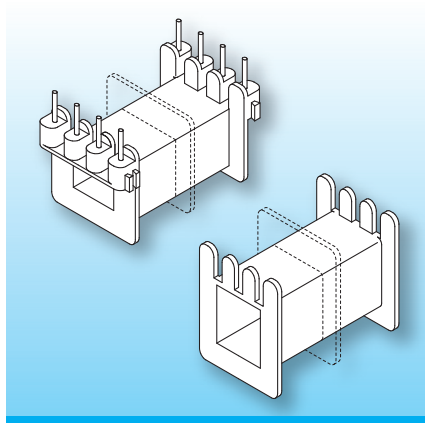

Due to their designs with different connection systems (press-fit pins, bent over pins, soldertags, etc.) the coilformer-versions allow radial as well as axial binding on of the wires, matching your individual fields of application. For special designs and dimensions as well as available accessories please contact our technical specialists.

Type	Order-Code	Accessories
Coilformer: 2UJ 48b/1k/2g2-/5.0-kv/p6g Solder-pin: h817/ua	09120-024 73503-212	on request

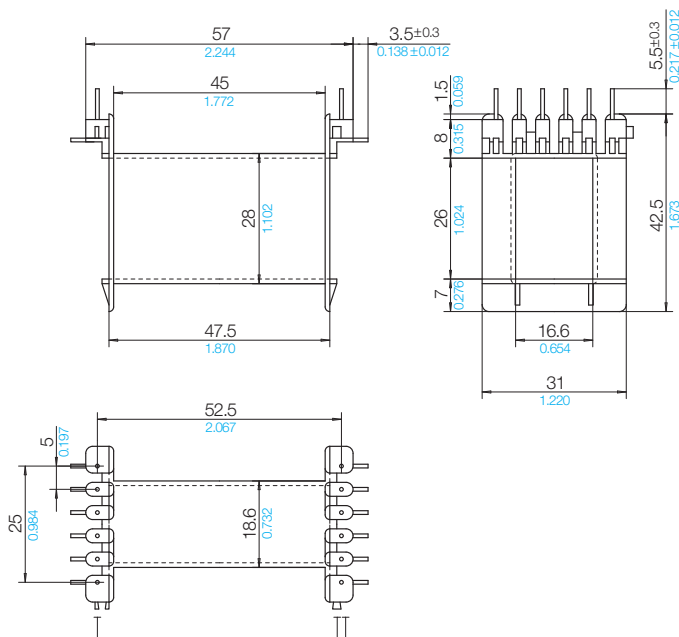

## Grid View pin-side

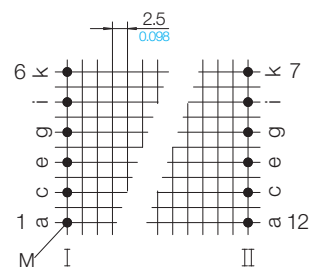

13 B 3 M

### © 11/2017 by NORWE GmbH

Warranties:  
refer to Terms and Conditions of Sale

### NORWE GmbH

Postfach 13 56  
51691 Bergneustadt  
Paulstraße 5, Pernze  
51702 Bergneustadt  
Deutschland  
Telefon +49 (0) 27 63-807-0  
Telefax +49 (0) 27 63-807-77  
E-mail verkauf@norwe.de  
Internet www.norwe.de  
www.norwe.eu

### NORWE Inc.

P.O. Box 25 11  
North Canton, OH 44720-0511  
United States of America  
Telefon +1-330 497-8113  
Telefax +1-330 305-0592  
E-mail usa@norwe.com  
Internet www.norwe.com



Valid version of  
data sheet online

QR Online-Version