

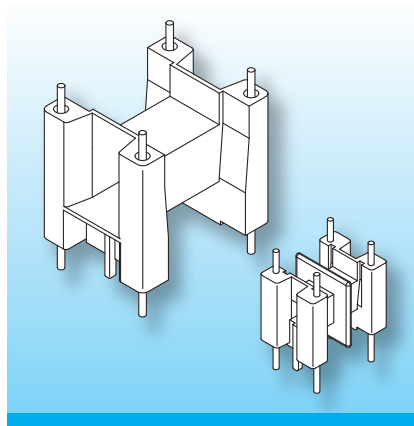

## U Standard Coilformers

The coilformers are made in gfr Polyamide PA66 of type p6g (RTI long-range temperature +125°C).  
Pin material: tin bronze, tinned.  
Maximum solder temperature 350°C, 2 sec.  
Special materials – e.g. irradiated cross-linked – and designs on request, dimensions in mm/inch.



The coilformers have through-hole round pins for contacts on both sides. The terminal strips usually feature "noses" which provide tension-relief, identification-noses (hole in the pcb) and "stand-offs" which allow clean soldering of the wires and of the coilformer onto the pcb.

Type	Order-Code	Accessories
Coilformer: U 10/1k/4-8/7.62-de/p6g	92147-024	Spring-Clip SB-U 10
Coilformer: U 10/2k/4-8/7.62-de/p6g	N0210-024 	
Solder-pin: m819/ua	70187-212	

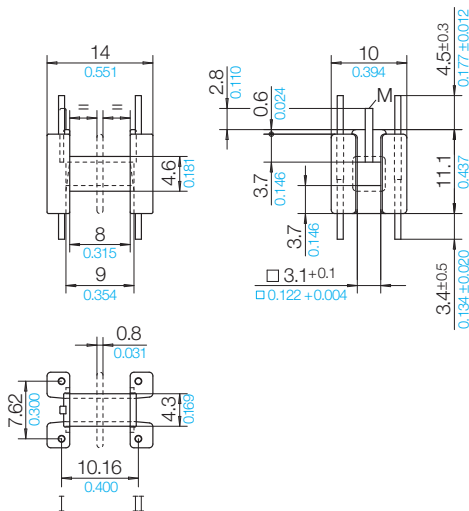

## Grid

View pin-side

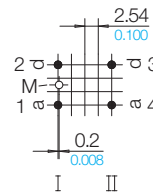

## © 08/2012 by NORWE GmbH

All dimensions in mm/inch

The permissible deviations according to DIN 16901 apply as tolerances

Warranties:  
refer to Terms and Conditions of Sale



Valid version of data sheet online

QR Online-Version

## NORWE GmbH

Postfach 13 56  
51691 Bergneustadt  
Paulstraße 5, Pernze  
51702 Bergneustadt

Deutschland

Telefon +49 (0) 27 63-807-0  
Telefax +49 (0) 27 63-807-77  
E-mail verkauf@norwe.de  
Internet www.norwe.de  
www.norwe.eu

## NORWE Inc.

P.O. Box 25 11  
North Canton, OH 44720-0511  
United States of America

Telefon +1-330 497-8113  
Telefax +1-330 305-0592  
E-mail usa@norwe.com  
Internet www.norwe.com