

EP-Coilformers with Solder-pins

The coilformers are made in gfr Polyethylene Terephthalate PET of type rtg nat. (RTI long-range temperature +155°C).

Pin material: tin bronze, tinned.

Maximum solder temperature 350°C, 2 sec.

Special materials – e.g. irradiated cross-linked – and designs on request, dimensions in mm/inch.

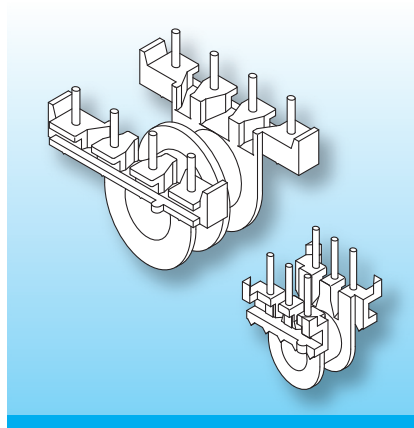

The coilformers are fitted with straight pins. Binding-on of the wires is axially. The terminal strips usually feature “noses” which provide tension-relief, and “stand-offs” which allow clean soldering of the wires and of the coilformer onto the pcb.

Type	Order-Code	Accessories
Coilformer: EP 20/1k/10-6/5.08-ih/rtg	90069-087	Spring-Clip SB-EP 20
Coilformer: EP 20/2k/10-6/5.08-ih/rtg	N0201-087 	
Coilformer: EP 20/1k/10-8/5.08-ih/rtg	90086-087	
Coilformer: EP 20/2k/10-8/5.08-ih/rtg	90087-087	
Solder-pin: z607/ua	73263-212	
Solder-pin: z807/ua	73293-212	

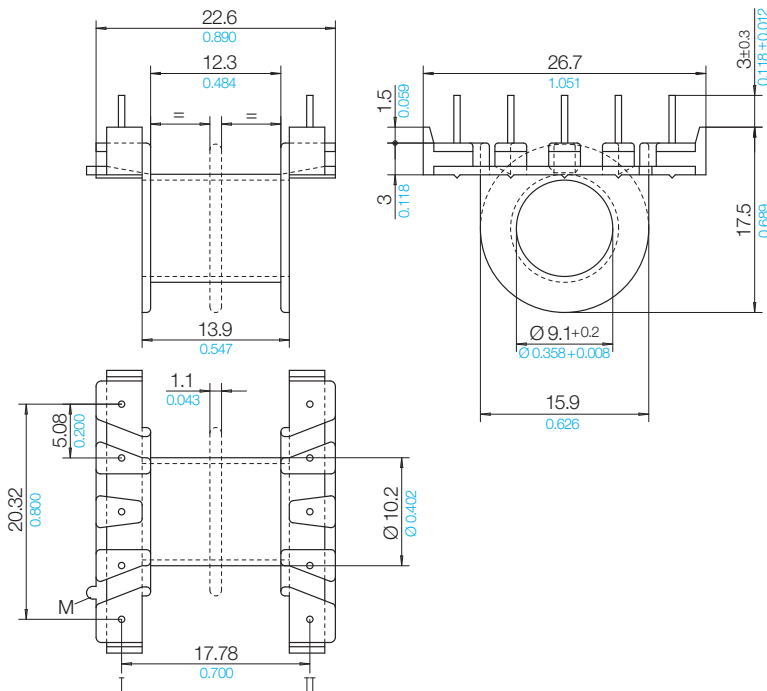

Grid
View pin-side

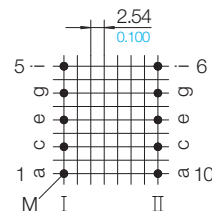

© 03/2012 by NORWE GmbH

All dimensions in mm/inch

The permissible deviations according to DIN 16901 apply as tolerances

Warranties:
refer to Terms and Conditions of Sale

NORWE GmbH

Postfach 13 56
51691 Bergneustadt
Paulstraße 5, Pernze
51702 Bergneustadt
Deutschland
Telefon +49 (0) 27 63-807-0
Telefax +49 (0) 27 63-807-77
E-mail verkauf@norwe.de
Internet www.norwe.de
www.norwe.eu

NORWE Inc.

P.O. Box 25 11
North Canton, OH 44720-0511
United States of America
Telefon +1-330 497-8113
Telefax +1-330 305-0592
E-mail usa@norwe.com
Internet www.norwe.com