

Spring-Clips SB-EP

Glueing methods are usually used to connect and secure the ferrite cores. Glues, such as Araldite, require the ferrite cores to be kept under constant pressure until the glue has hardened. A more advantageous and quicker method is by using stainless steel clips SB. The holding pressure is almost constant over the whole operating temperature range.

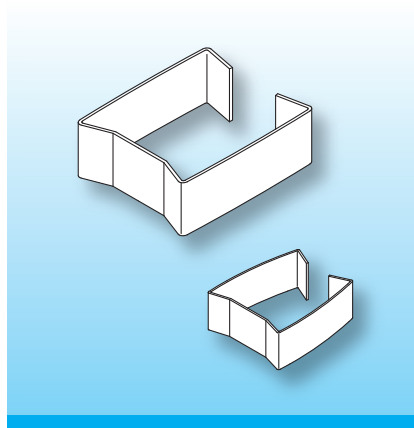

One clip is required to assemble a wound coilformer with one pair of ferrite cores. The use of a drop of glue is recommended, to connect the ferrites to the coilformer and to prevent frequency noise. Dimensions in mm/inch.

When ordering please quote type and order-code.

Type	Order-Code	A	B	C	D	I
SB-EP 7/sa	78955-085	9.6 0.378	8.5 0.335	5.0 0.197	2.5 0.098	0.25 0.010
SB-EP 10/sa	78956-085	12.0 0.472	11.5 0.453	6.0 0.236	3.0 0.118	0.25 0.010
SB-EP 13/sa	78957-085	13.0 0.512	14.2 0.559	7.5 0.295	4.0 0.157	0.30 0.012
SB-EP 17/sa	78958-085	18.7 0.736	18.4 0.724	8.0 0.315	5.0 0.197	0.30 0.012
SB-EP 20/sa	78959-085	24.7 0.972	23.0 0.906	10.0 0.394	6.0 0.236	0.30 0.012

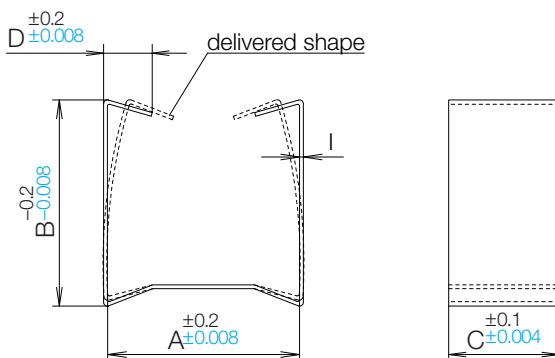

© 03/2012 by NORWE GmbH

All dimensions in mm/inch

The permissible deviations according to DIN 16901 apply as tolerances

Warranties:
refer to Terms and Conditions of Sale

NORWE GmbH

Postfach 13 56
51691 Bergneustadt
Paulstraße 5, Pernze
51702 Bergneustadt
Deutschland
Telefon +49 (0) 27 63-807-0
Telefax +49 (0) 27 63-807-77
E-mail verkauf@norwe.de
Internet www.norwe.de
www.norwe.eu

NORWE Inc.

P.O. Box 25 11
North Canton, OH 44720-0511
United States of America
Telefon +1-330 497-8113
Telefax +1-330 305-0592
E-mail usa@norwe.com
Internet www.norwe.com