

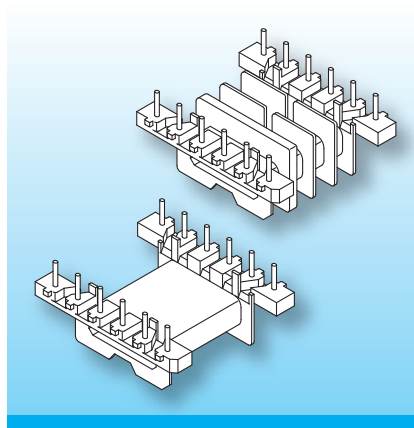

## EFD – Coilformers with z8 Solder-pins

The coilformers are made in gr Polyamide PA66 of type A3X2G10 (RTI long-range temperature +115°C).  
 Pin material: tin bronze, tinned.  
 Maximum solder temperature 350°C, 2 sec.  
 Special materials – e.g. irradiated cross-linked – and designs on request, dimensions in mm/inch.



The coilformers are fitted with straight, sturdy z8 pins. Binding-on of the wires is axially. The pins are suitable for windings with thick wire. The terminal strips usually feature “noses” which provide tension-relief, and “stand-offs” which allow clean soldering of the wires and of the coilformer onto the pcb.

Type	Order-Code	Accessories
Coilformer: EFD 25/1k/10-8/2.5/A3X2G10	94325-181	on request
Coilformer: EFD 25/1-3ks/10-8/2.5/A3X2G10	N0188-181	 on request
Solder-pin: z808/ua	73294-212	
Solder-pin: z809/ua	73295-212	

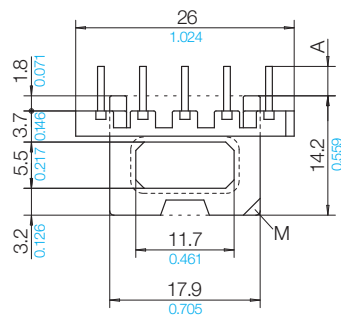
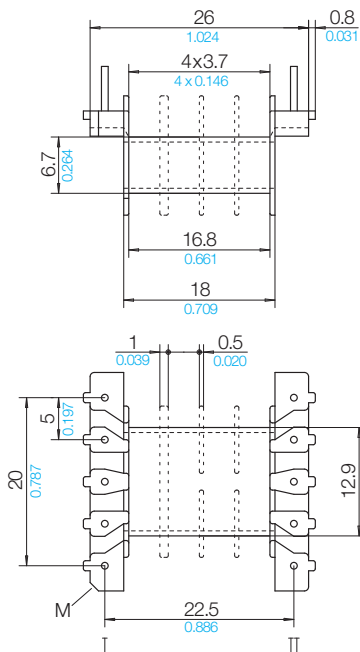

**Grid**  
View pin-side

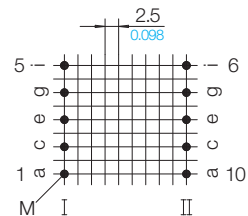

z808 A=3.5±0.3/0.138±0.012  
 without Potting Box  
 z809 A=4.5±0.3/0.177±0.012  
 for Potting Box

© 01/2012 by NORWE GmbH

All dimensions in mm/inch

The permissible deviations according to DIN 16901 apply as tolerances

Warranties:  
 refer to Terms and Conditions of Sale

**NORWE GmbH**

Postfach 13 56  
 51691 Bergneustadt  
 Paulstraße 5, Pernze  
 51702 Bergneustadt  
 Deutschland  
 Telefon +49 (0) 27 63-807-0  
 Telefax +49 (0) 27 63-807-77  
 E-mail verkauf@norwe.de  
 Internet www.norwe.de  
 www.norwe.eu

**NORWE Inc.**

P.O. Box 25 11  
 North Canton, OH 44720-0511  
 United States of America  
 Telefon +1-330 497-8113  
 Telefax +1-330 305-0592  
 E-mail usa@norwe.com  
 Internet www.norwe.com