

Clips SB-EFD

Glueing methodes are usually used to connect and secure the ferrite cores. Glues, such as Araldite, require the ferrite cores to be kept under constant pressure until the glue has hardened. A more advantageous and quicker method is by using stainless steel clips SB. The holding pressure is almost constant over the whole operating temperature range.

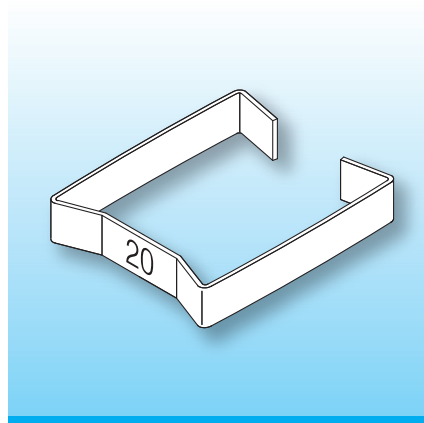

One clip is required to assemble a wound coilformer with one pair of ferrite cores. The use of a drop of glue is recommended, to connect the ferrites to the coilformer and to prevent frequency noise. Dimension in mm.

When ordering please quote type and order-code.

Type	Order-Code	A	B	C	D	I
SB-EFD 15/sa	78990-085	15.5	16.3	3.0	3.0	0.20
SB-EFD 20/sa	78991-085	0.610	0.642	0.118	0.118	0.008
SB-EFD 25/sa	N0382-085	20.7	21.5	3.5	4.0	0.25
SB-EFD 30/sa	N0383-085	0.815	0.846	0.138	0.157	0.010
		25.8	26.7	5.0	5.0	0.25
		1.016	1.051	0.197	0.197	0.010
		30.9	31.9	5.5	6.0	0.25
		1.217	1.256	0.217	0.236	0.010

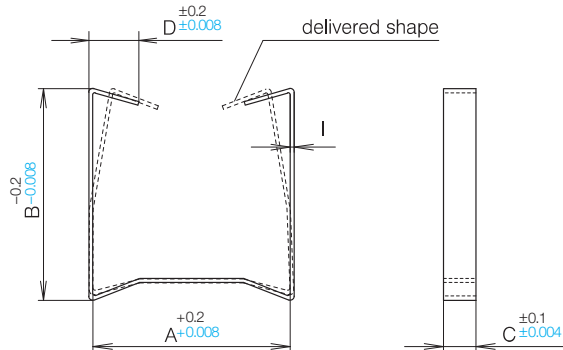

© 04/2016 by NORWE GmbH

Warranties:
refer to Terms and Conditions of Sale

NORWE GmbH

Postfach 13 56
51691 Bergneustadt
Paulstraße 5, Pernze
51702 Bergneustadt
Deutschland

Telefon +49 (0) 27 63-807-0
Telefax +49 (0) 27 63-807-77
E-mail verkauf@norwe.de
Internet www.norwe.de
www.norwe.eu

NORWE Inc.

P.O. Box 25 11
North Canton, OH 44720-0511
United States of America
Telefon +1-330 497-8113
Telefax +1-330 305-0592
E-mail usa@norwe.com
Internet www.norwe.com



Valid version of
data sheet online

QR Online-Version