

## Spring-Clips SB-SMD

The Spring-Clips are for assembling the ferrite cores and holding them together. The process is simple and cost-effective. The clips surround the whole outside of the ferrite cores and keep them under constant pressure. Variations of operating temperature has no effect on clamping pressure. One clip is required per assembly.

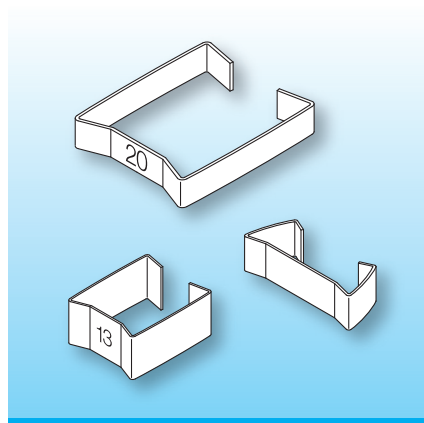

Special materials and designs on request, dimensions in mm/*inch*.

When ordering please quote type and order-code.

Type I	Order-Code		A	B	C	D	I
SB – EF 5/sa	N0356-085	on request	5.4 0.213	6.0 0.236	2.0 0.079	1.6 0.063	0.15 0.006
SB – EF 6.3/sa	N0378-085	on request	6.6 0.260	6.0 0.236	2.0 0.079	1.8 0.071	0.15 0.006
SB – EF 8/sa	N0133-085	on request	8.2 0.323	8.8 0.346	2.0 0.079	2.0 0.079	0.15 0.006
SB – EF 8.8/sa	N0379-085	on request	9.5 0.374	9.0 0.354	2.0 0.079	2.0 0.079	0.20 0.008
SB – EF 10/sa	N0134-085	on request	10.3 0.406	10.8 0.425	2.5 0.098	2.5 0.098	0.20 0.008
SB – EF 12.6/sa	78940-085		13.1 0.516	14.0 0.551	3.5 0.138	3.0 0.118	0.25 0.010
SB – EF 16/sa	78941-085		16.7 0.657	17.4 0.685	4.5 0.177	4.0 0.157	0.30 0.012
SB – EF/E 20/sa	78942-085		20.8 0.819	21.6 0.850	5.5 0.217	5.0 0.197	0.30 0.012

### Type I

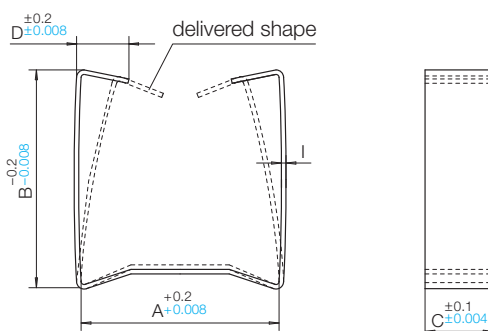

shown Spring-Clip SB-EF 10

© 04/2018 by NORWE GmbH

Warranties:  
refer to Terms and Conditions of Sale

**NORWE GmbH**

Postfach 13 56  
51691 Bergneustadt  
Paulstraße 5, Pernze  
51702 Bergneustadt  
Deutschland  
Telefon +49 (0) 27 63-807-0  
Telefax +49 (0) 27 63-807-77  
E-mail verkauf@norwe.de  
Internet www.norwe.de  
www.norwe.eu

**NORWE Inc.**

P.O. Box 25 11  
North Canton, OH 44720-0511  
United States of America  
Telefon +1-330 497-8113  
Telefax +1-330 305-0592  
E-mail usa@norwe.com  
Internet www.norwe.com



Valid version of  
data sheet online

QR Online-Version

## Spring-Clips SB-SMD

The Spring-Clips are for assembling the ferrite cores and holding them together. The process is simple and cost-effective. The clips surround the whole outside of the ferrite cores and keep them under constant pressure. Variations of operating temperature has no effect on clamping pressure. One clip is required per assembly.

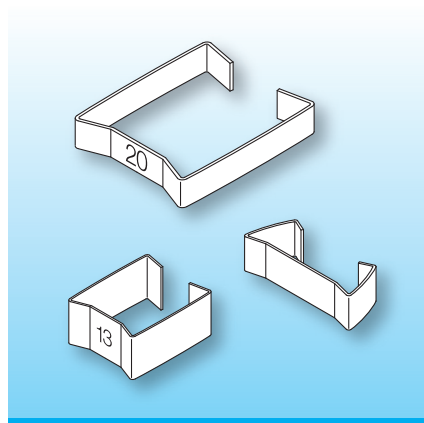

Special materials and designs on request, dimensions in mm/*inch*.

When ordering please quote type and order-code.

Type II	Order-Code		A	B	C	D	I
SB – EFD 10/sa	N0380-085	on request	10.9 0.429	11.4 0.449	2.5 0.098	2.5 0.098	0.20 0.008
SB – EFD 12/sa	N0381-085	on request	12.9 0.508	13.6 0.535	3.0 0.118	3.0 0.118	0.20 0.008
SB – EFD 15/sa	78990-085		15.5 0.610	16.3 0.642	3.0 0.118	3.0 0.118	0.20 0.008
SB – EFD 20/sa	78991-085		20.7 0.815	21.5 0.846	3.5 0.138	1.6 0.063	0.25 0.010
SB – EFD 25/sa	N0382-085	on request	25.8 1.016	26.7 1.051	5.0 0.197	1.7 0.067	0.25 0.010
SB – EFD 30/sa	N0383-085	on request	30.9 1.217	31.9 1.256	5.5 0.217	1.8 0.071	0.25 0.010

## Type II

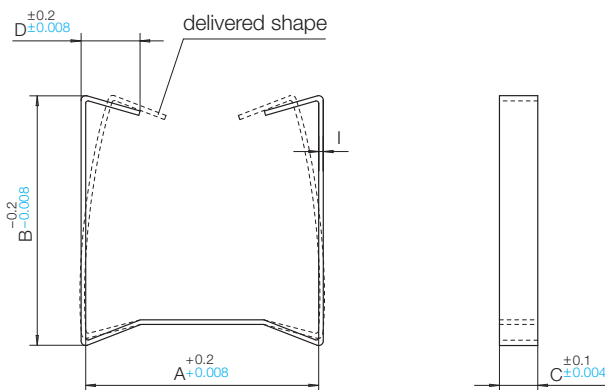

shown Spring-Clip SB-EFD 20

© 04/2018 by NORWE GmbH

Warranties:  
refer to Terms and Conditions of Sale



Valid version of  
data sheet online

QR Online-Version

**NORWE GmbH**

Postfach 13 56  
51691 Bergneustadt  
Paulstraße 5, Pernze  
51702 Bergneustadt  
Deutschland

Telefon +49 (0) 27 63-807-0  
Telefax +49 (0) 27 63-807-77  
E-mail [verkauf@norwe.de](mailto:verkauf@norwe.de)  
Internet [www.norwe.de](http://www.norwe.de)  
[www.norwe.eu](http://www.norwe.eu)

**NORWE Inc.**

P.O. Box 25 11  
North Canton, OH 44720-0511  
United States of America  
Telefon +1-330 497-8113  
Telefax +1-330 305-0592  
E-mail [usa@norwe.com](mailto:usa@norwe.com)  
Internet [www.norwe.com](http://www.norwe.com)

## Spring-Clips SB-SMD

The Spring-Clips are for assembling the ferrite cores and holding them together. The process is simple and cost-effective. The clips surround the whole outside of the ferrite cores and keep them under constant pressure. Variations of operating temperature has no effect on clamping pressure. One clip is required per assembly.

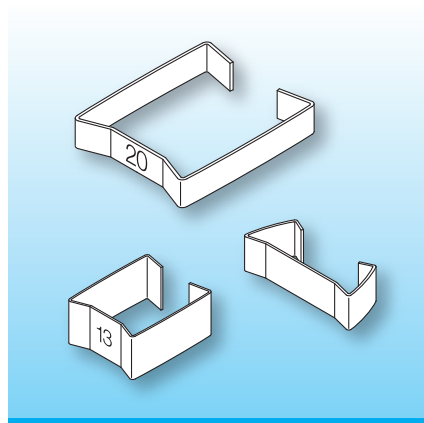

Special materials and designs on request, dimensions in mm/*inch*.

When ordering please quote type and order-code.

Type III	Order-Code	A	B	C	D	I
SB – ER 9.5/5/sa	78920-085	9.6 0.378	5.5 0.217	4.0 0.157	2.5 0.098	0.15 0.006
SB – ER 11/5/sa	78921-085	11.1 0.437	5.5 0.217	4.5 0.177	3.0 0.118	0.15 0.006
SB – ER 14.5/6/sa	N0384-085	14.7 0.579	6.5 0.256	5.0 0.197	4.0 0.157	0.20 0.008

on request

Type IV	Order-Code	A	B	C	D	I
SB – EP 5/sa	N0385-085	6.4 0.252	6.7 0.264	3.0 0.118	2.0 0.079	0.20 0.008
SB – EP 7/sa	78955-085	9.6 0.378	8.5 0.335	5.0 0.197	2.5 0.098	0.25 0.010
SB – EP 10/sa	78956-085	12.0 0.472	11.5 0.453	6.0 0.236	3.0 0.118	0.25 0.010
SB – EP 13/sa	78957-085	13.0 0.512	14.2 0.559	7.5 0.295	4.0 0.157	0.30 0.012

on request

### Type III

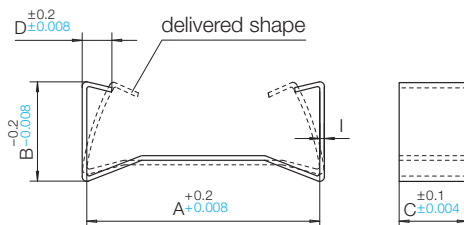

shown Spring-Clip SB-ER 9.5

### Type IV

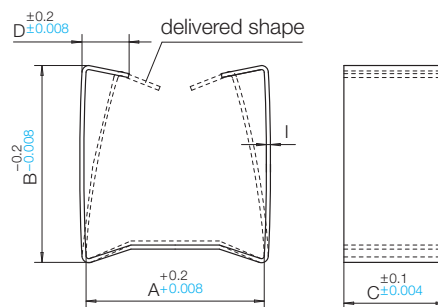

shown Spring-Clip SB-EP 13

© 04/2018 by NORWE GmbH

Warranties:  
refer to Terms and Conditions of Sale

**NORWE GmbH**

Postfach 13 56  
51691 Bergneustadt  
Paulstraße 5, Pernze  
51702 Bergneustadt  
Deutschland  
Telefon +49 (0) 27 63-807-0  
Telefax +49 (0) 27 63-807-77  
E-mail verkauf@norwe.de  
Internet www.norwe.de  
www.norwe.eu

**NORWE Inc.**

P.O. Box 25 11  
North Canton, OH 44720-0511  
United States of America  
Telefon +1-330 497-8113  
Telefax +1-330 305-0592  
E-mail usa@norwe.com  
Internet www.norwe.com



Valid version of  
data sheet online

QR Online-Version