

EFD-SMD Coilformers (fu)

The coilformers are made in gfr Polyphenylene Sulfide PPS of type torA504 (RTI long-range temperature +130°C) and are suitable for reflow soldering.
Pin material: tin bronze, tinned.
Special materials – e.g. irradiated cross-linked – and designs on request, dimensions in mm/[inch](#).

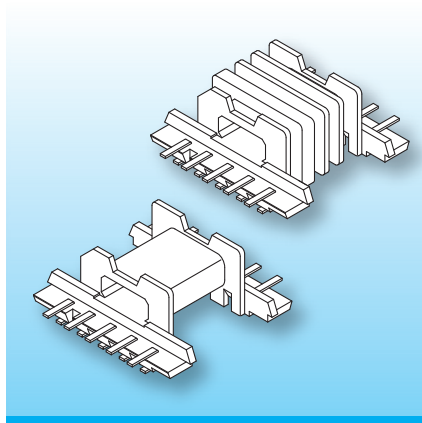

The coilformers are fitted with U-shaped terminals. The two sides of the terminal allow automatic binding-on and soldering of the wires, leaving the pcb-side of the terminal free from tin.
Automatic placing of the coilformer and the ferrites is possible by using a Snap-on Cap. This cap is spring-loaded and keeps the ferrites and coilformer together. The coilformers are available with single, double and four sections.

Type	Order-Code	Accessories
Coilformer: EFD 20-SMD2/1k/8f-625-/torA504	94303-132	Snap-on Cap EFD 20/FG
Coilformer: EFD 20-SMD2/2k/8f-625-/torA504	94307-132	Spring-Clip SB-EFD 20
Coilformer: EFD 20-SMD2/1-3ks/8f-625-/torA504	N0312-132	on request
Solder-pin: fu625-70/ub	75829-213	

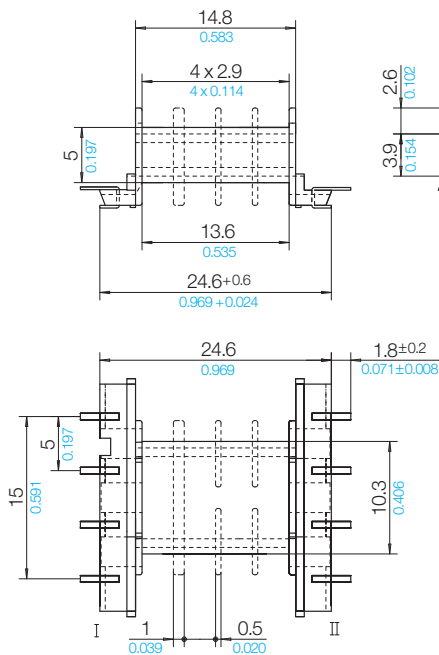

Pin Connecting Surface

View pin-side

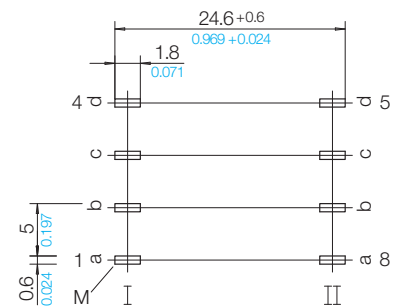

© 06/2014 by NORWE GmbH

Warranties:
refer to Terms and Conditions of Sale

NORWE GmbH

Postfach 13 56
51691 Bergneustadt
Paulstraße 5, Pernze
51702 Bergneustadt
Deutschland
Telefon +49 (0) 27 63-807-0
Telefax +49 (0) 27 63-807-77
E-mail verkauf@norwe.de
Internet www.norwe.de
www.norwe.eu

NORWE Inc.

P.O. Box 25 11
North Canton, OH 44720-0511
United States of America
Telefon +1-330 497-8113
Telefax +1-330 305-0592
E-mail usa@norwe.com
Internet www.norwe.com



Valid version of
data sheet online

QR Online-Version