

## EP-SMD Coilformers (fu)

The coilformers are made in gfr Polyphenylene Sulfide PPS of type torA504 (RTI long-range temperature +130°C) and are suitable for reflow soldering.  
Pin material: tin bronze, tinned.  
Special materials – e.g. irradiated cross-linked – and designs on request, dimensions in mm/inch).

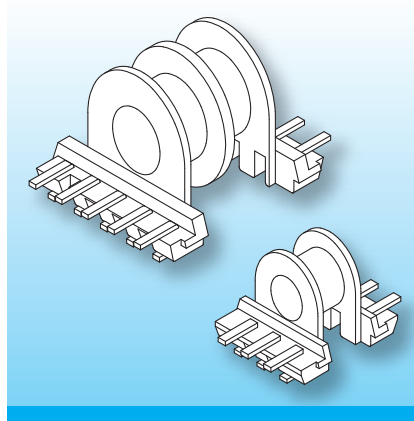

The coilformers are fitted with U-shaped terminals. The two sides of the terminals allow automatic binding-on and soldering of the wires, leaving the pcb-side of the terminal free from tin. Instead of glueing the ferrites, use can be made of the SB-EP Spring-Clips. Automatic placing of the coilformer and the ferrites is possible by using a Snap-on Cap. This cap is spring-loaded and keeps the ferrites and coilformer together. Slots in the Snap-on Caps allow additional glueing.

Type	Order-Code	Accessories
Coilformer: EP 13-SMD2/1k/10f-625-/torA504	90150-132	Snap-on Cap EP 13/FG
Coilformer: EP 13-SMD2/2k/10f-625-/torA504	90151-132	Spring-Clip SB-EP 13
Solder-pin: fu625-67/ub	75826-213	Latching-Clip FB-EP 13

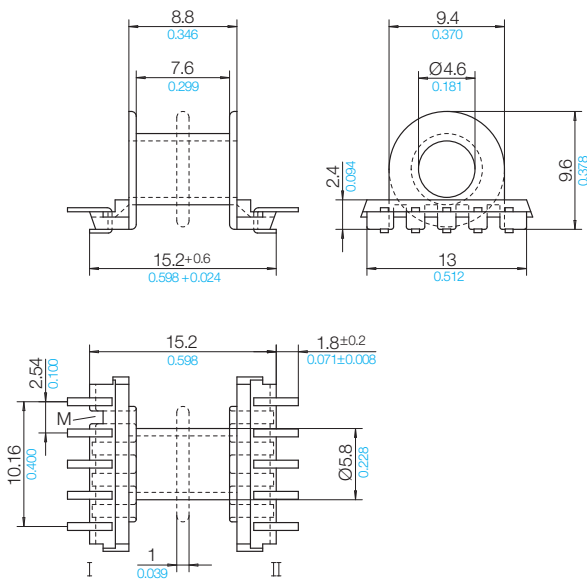

## Pin Connecting Surface View pin-side

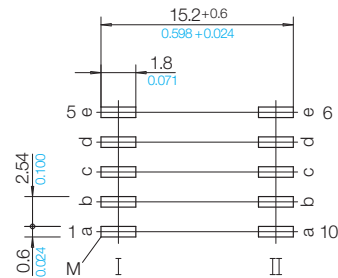

## © 11/2011 by NORWE GmbH

All dimensions in mm/inch

The permissible deviations according to DIN 16901 apply as tolerances

Warranties:  
refer to Terms and Conditions of Sale

## NORWE GmbH

Postfach 13 56  
51691 Bergneustadt  
Paulstraße 5, Pernze  
51702 Bergneustadt  
Deutschland  
Telefon +49 (0) 27 63-807-0  
Telefax +49 (0) 27 63-807-77  
E-mail verkauf@norwe.de  
Internet www.norwe.de  
www.norwe.eu

## NORWE Inc.

P.O. Box 25 11  
North Canton, OH 44720-0511  
United States of America  
Telefon +1-330 497-8113  
Telefax +1-330 305-0592  
E-mail usa@norwe.com  
Internet www.norwe.com