

RM-SMD Coilformers (fm)

The coilformers are made in gfr Polyphenylene Sulfide PPS of type torA504 (RTI long-range temperature +130°C) and are suitable for reflow soldering.
Pin material: tin bronze, tinned.
Special materials – e.g. irradiated cross-linked – and designs on request, dimensions in mm/inch).

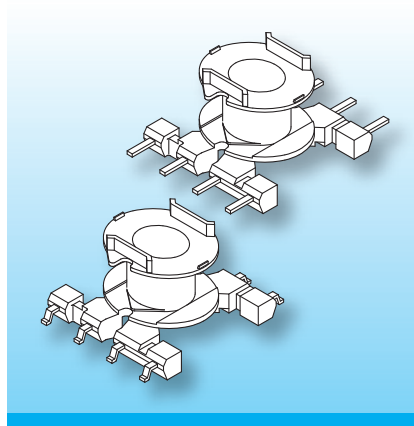

The slot-design from the terminals into the winding section is suitable to accommodate wire guidance without change of the guide-axis. The tolerance compensator TA on the top flange eliminates the otherwise required insulation-washer. To prevent melt-out, the terminals should ideally be mechanically fixed when soldering.

Type	Order-Code	Accessories
Coilformer: RM 6-SMD1/8f-625-/torA504	90128-132	
Solder-pin: fm625-40/ub	75803-213	
Solder-pin: f625-40/ub	75854-213	

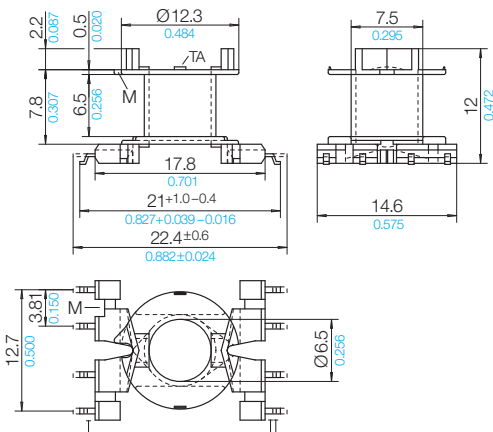

Pin Connecting Surface View pin-side

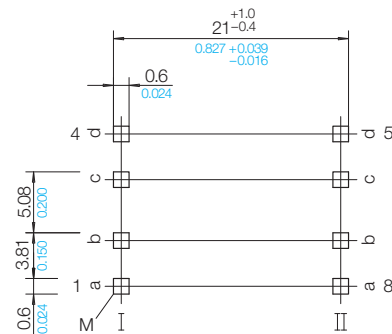

© 07/2011 by NORWE GmbH

All dimensions in mm/inch

The permissible deviations according to DIN 16901 apply as tolerances

Warranties:
refer to Terms and Conditions of Sale

NORWE GmbH

Postfach 13 56
51691 Bergneustadt
Paulstraße 5, Pernze
51702 Bergneustadt
Deutschland
Telefon +49 (0) 27 63-807-0
Telefax +49 (0) 27 63-807-77
E-mail verkauf@norwe.de
Internet www.norwe.de
www.norwe.eu

NORWE Inc.

P.O. Box 25 11
North Canton, OH 44720-0511
United States of America
Telefon +1-330 497-8113
Telefax +1-330 305-0592
E-mail usa@norwe.com
Internet www.norwe.com