

## PC Connecting Boards

The connecting boards are made in gfr Polyethylene Terephthalate PET of type rtg nat. (RTI long-range temperature 155°C).

Pin material: tin bronze, tinned.  
Maximum solder temperature 350°C, 2 sec.

Special materials – e.g. irradiated cross-linked – and designs on request, dimensions in mm/*inch*.

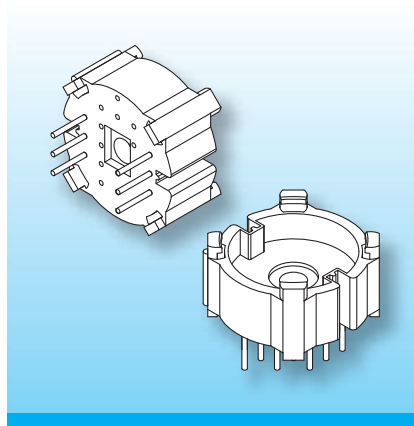

Binding-on of the wires to the connecting board can be done using the NORWE mandrel assembly. The wires are insulated to the ferrite core, routing through side-channels in the connecting board. A snap-in insulating cap completes the pot-core assembly.

Type	Order-Code	Accessories
Connecting Board: AT 36 x 22/-6/rtg Solder-pin: z608/ua	N0154-087  73264-212	Coilformers 30x19 Insulating Cap 30x19

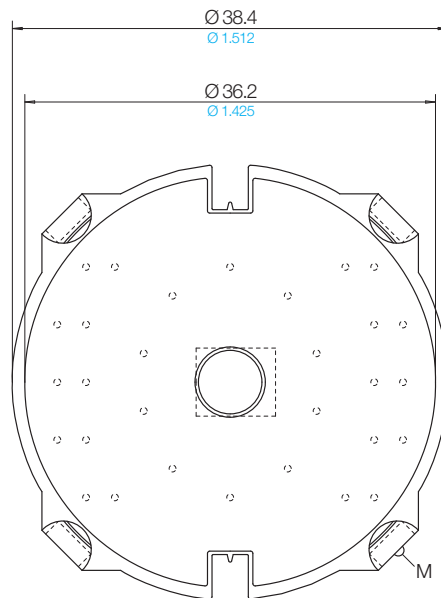
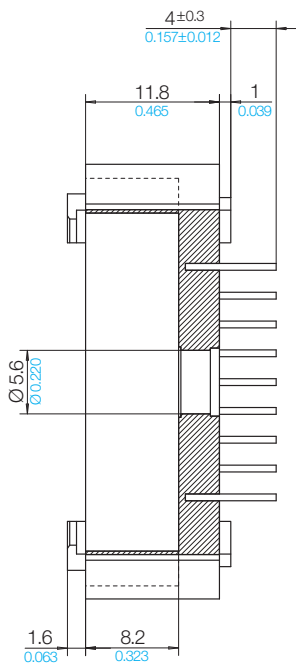

**Grid**  
View pin-side

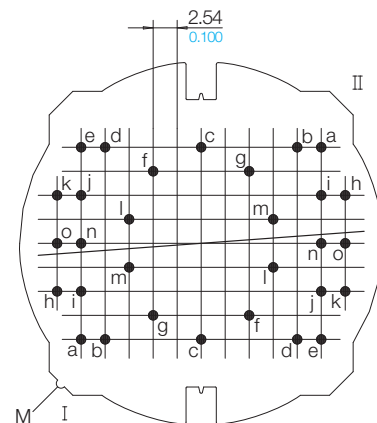

### © 02/2012 by NORWE GmbH

All dimensions in mm/*inch*

The permissible deviations according to DIN 16901 apply as tolerances

Warranties:  
refer to Terms and Conditions of Sale

### NORWE GmbH

Postfach 13 56  
51691 Bergneustadt  
Paulstraße 5, Pernze  
51702 Bergneustadt  
Deutschland  
Telefon +49 (0) 27 63-807-0  
Telefax +49 (0) 27 63-807-77  
E-mail verkauf@norwe.de  
Internet www.norwe.de  
www.norwe.eu

### NORWE Inc.

P.O. Box 25 11  
North Canton, OH 44720-0511  
United States of America  
Telefon +1-330 497-8113  
Telefax +1-330 305-0592  
E-mail usa@norwe.com  
Internet www.norwe.com