

PC Coilformers with integral Connecting Boards

The coilformers are made in gfr Polyethylene Terephthalate PET of type rtg nat. (RTI long-range temperature +155° C).
Pin material: tin bronze, tinned.
Maximum solder temperature 350° C, 2 sec.
Special materials – e.g. irradiated cross-linked – and designs on request, dimensions in mm/inch.

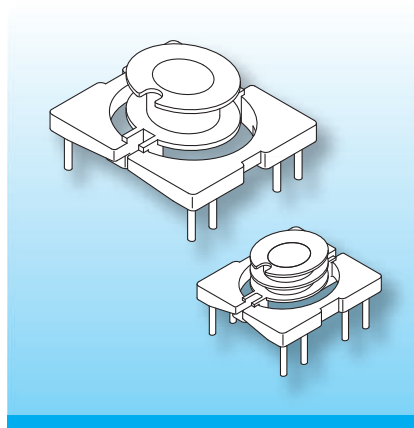

The coils in pot-core assemblies are almost totally enclosed by the ferrite cores, resulting in low leakage and low electromagnetic interference. The integral terminals and channels for routing the wires allow fully automated winding on NC-winding machines. "Stand-offs" allow clean soldering of the wires and of the coilformer onto the pcb.

Type	Order-Code	Accessories
Coilformers with integral Connecting Boards:		on request
PC-A 9 x 5/-6/rtg	1 6081 -087	
PC-A 9 x 5/2k/-6/rtg	1 6086 -087	
Solder-pin: z606/ua	7 3262 -212	

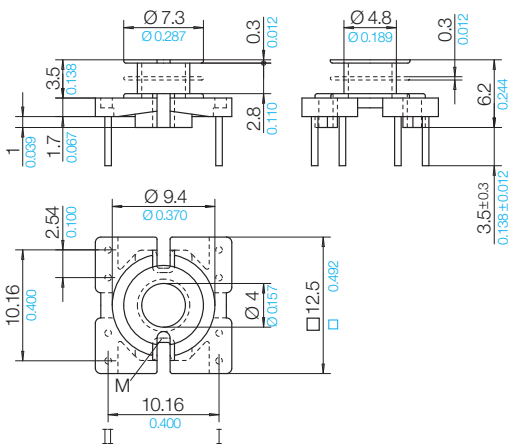

Grid View pin-side

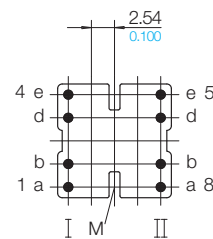

© 02/2012 by NORWE GmbH

All dimensions in mm/inch

The permissible deviations according to DIN 16901 apply as tolerances

Warranties:
refer to Terms and Conditions of Sale

NORWE GmbH

Postfach 13 56
51691 Bergneustadt
Paulstraße 5, Pernze
51702 Bergneustadt
Deutschland
Telefon +49 (0) 27 63-807-0
Telefax +49 (0) 27 63-807-77
E-mail verkauf@norwe.de
Internet www.norwe.de
www.norwe.eu

NORWE Inc.

P.O. Box 25 11
North Canton, OH 44720-0511
United States of America
Telefon +1-330 497-8113
Telefax +1-330 305-0592
E-mail usa@norwe.com
Internet www.norwe.com