

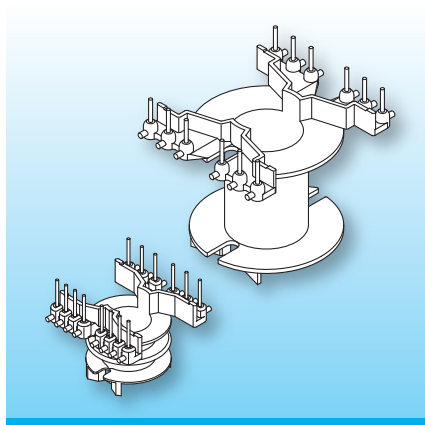

## PQ Coilformers with Dual-in-Line Solder-pins.

The coilformers are made in gfr Polyethylene Terephthalate PET of type SKYT.5220FR (long-range temperature +155° C). Pin material: tin bronze, tinned. Maximum solder temperature 350° C for up to 2 sec. (Special materials – for example radiated cross-linked – and designs on request. Dimensions in mm/*inch*).



The coilformers with vertical axis are suitable for winding on the latest NC machines. The DIL pin configuration with radial "noses" ensures tension relieved axial binding-on of the wires. "Stand-offs" minimize cold-solder joints into the pcb.

Type	Order-Code	Accessories
Coilformer: PQ 26-20/1k/-8/jk/SKYT.5220FR	90364-186	on request
Coilformer: PQ 26-20/2k/-8/jk/SKYT.5220FR	N0505-186 	
Solder-pin: z809/ua	73295-212	

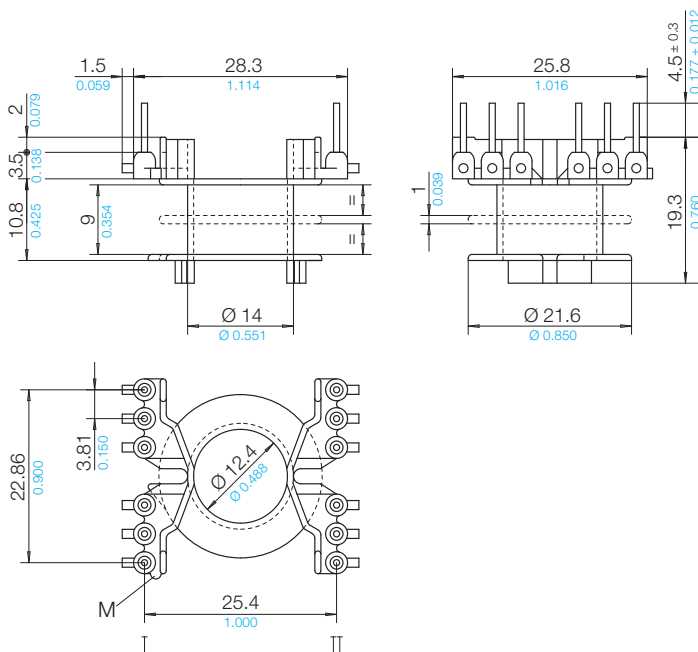

**Grid**  
View pin-side

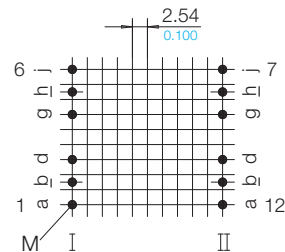

04 B 0 K

**© 09/2022 by NORWE GmbH**

All dimensions in mm/inch

The permissible deviations according to DIN 16901 apply as tolerances

Warranties: refer to Terms and Conditions of Sale



Valid version of data sheet online

QR Online-Version

**NORWE GmbH**

Paulstraße 5, Pernze  
51702 Bergneustadt  
Deutschland

Telefon +49 (0) 27 63-807-0  
E-mail [verkauf@norwe.de](mailto:verkauf@norwe.de)  
Internet [www.norwe.de](http://www.norwe.de)  
[www.norwe.eu](http://www.norwe.eu)

**NORWE Inc.**

P.O. Box 25 11  
North Canton, OH 44720-0511  
United States of America

Telefon +1-330 497-8113  
E-mail [usa@norwe.com](mailto:usa@norwe.com)  
Internet [www.norwe.com](http://www.norwe.com)