

Standard RM with Dual-in-Line solder-tags

The coilformers are made in gfr Polyethylene Terephthalate PET of type rtg nat. (RTI long-range temperature +155°C), Polyamide PA66 of type p6g (RTI long-range temperature +125°C) and A3X2G10 (RTI long-range temperature +115°C). Tag material: brass, tinned. Maximum solder temperature 350°C, 2 sec.

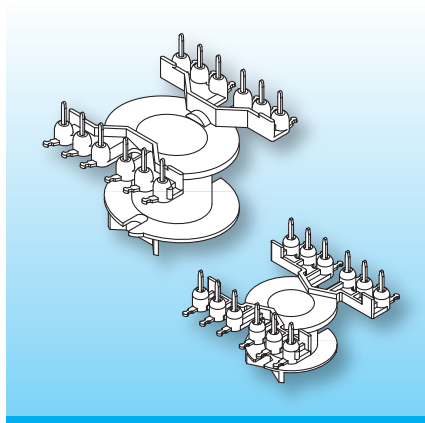

The coilformers have two rows of solder-tags, pcb-style dual-in-line. Binding-on of thin wire and litz can be done radially, and tension relief is possible. A tolerance-compensator (TA) on the top flange eliminates the normally used spring-washer. Special materials – eg. irradiated cross-linked – and designs on request, dimensions in mm/[inch](#).

Type

Coilformer: RM 6/1k/8-s/fg/rtg
Solder-tag: s25/wd

Order-Code

90075-087
75519-261

Accessories

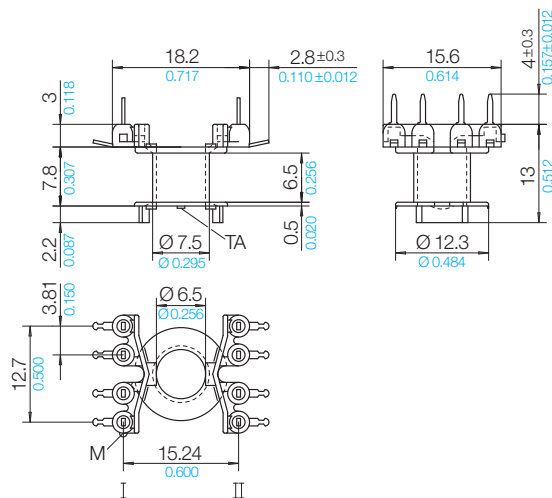

Grid

View tag-side

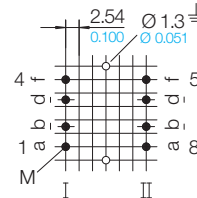

03 B 2 G

© 10/2017 by NORWE GmbH

Warranties:
refer to Terms and Conditions of Sale

NORWE GmbH

Postfach 13 56
51691 Bergneustadt
Paulstraße 5, Pernze
51702 Bergneustadt
Deutschland
Telefon +49 (0) 27 63-807-0
Telefax +49 (0) 27 63-807-77
E-mail verkauf@norwe.de
Internet www.norwe.de
www.norwe.eu

NORWE Inc.

P.O. Box 25 11
North Canton, OH 44720-0511
United States of America
Telefon +1-330 497-8113
Telefax +1-330 305-0592
E-mail usa@norwe.com
Internet www.norwe.com



Valid version of
data sheet online

QR Online-Version