

Standard RM, RM-LP Low Profile with Dual-in-Line solder-pins

The coilformers are made in gfr Polyethylene Terephthalate PET of type rtg nat. (RTI long-range temperature +155°C) and made in gfr Polyamide PA66 of type p6g (RTI long-range temperature +125°C). Pin material: tin bronze, tinned. Maximum solder temperature 350°C, 2 sec. Special materials – eg. irradiated cross-linked – and designs on request, dimensions in mm/*inch*.

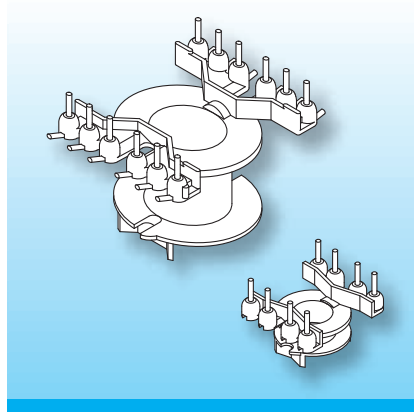

Two types of Dual-in-Line solder-pins can be fitted.
L-shaped type h for radial binding on, side wrapping and soldering. Tension relief for thin or litz wire is possible.
Straight solder-pins type z for axial binding-on and soldering. Less pcb area is required using this solder-pin.

Type	Order-Code	Accessories
Coilformer: RM 10/mF/1k/12-8/il/rtg	90072-087	
Solder-pin: h811/ua	73497-212	
Solder-pin: z807/ua	73293-212	

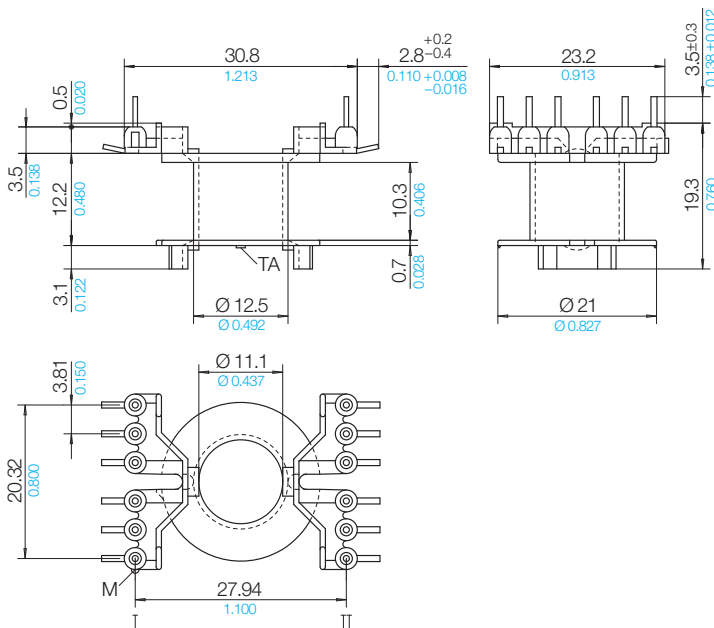

Grid View pin-side

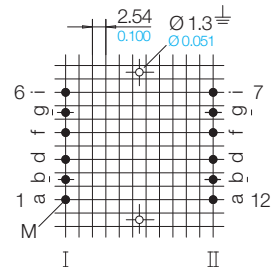

© 11/2011 by NORWE GmbH

All dimensions in mm/inch

The permissible deviations according to DIN 16901 apply as tolerances

Warranties:
refer to Terms and Conditions of Sale

NORWE GmbH

Postfach 13 56
 51691 Bergneustadt
 Paulstraße 5, Pernze
 51702 Bergneustadt
 Deutschland
 Telefon +49 (0) 27 63-807-0
 Telefax +49 (0) 27 63-807-77
 E-mail verkauf@norwe.de
 Internet www.norwe.de
 www.norwe.eu

NORWE Inc.

P.O. Box 25 11
 North Canton, OH 44720-0511
 United States of America
 Telefon +1-330 497-8113
 Telefax +1-330 305-0592
 E-mail usa@norwe.com
 Internet www.norwe.com