

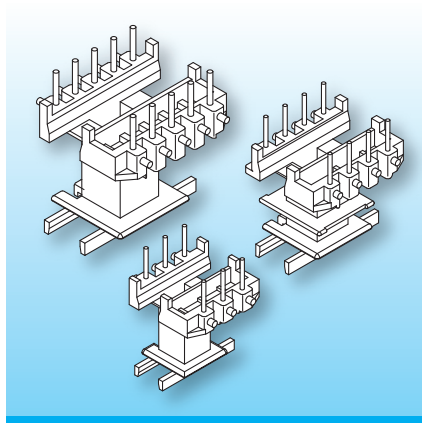

EE 12.6 – EE 25 Vertical/ longer creepage

The coilformers are made in gfr Polyamide PA66 of type A RV250 nat. (RTI long-range temperature +100 °C). Pin material is tin bronze, tinned. Maximum solder temperature 350 °C, 2sec.

Special materials – e.g. irradiated cross-linked – and designs on request, dimensions in mm/*inch*.



NORWE now is designing to expand the series of EE/M coilformers vertical EE 12.6 to EE 25 with longer creepage-dimensions between ferrite and solder-pin. The design allows automatic winding also on NC winding machines. Special winding noses and also a wire routing provide tension-relief when binding on the wire. The coilformers have distance strips to avoid cold-solder joints into the PCB.

Type	Order-Code	Accessories
Coilformer: EE 20/1k/K12/9-8/5.0-eg/A RV250 nat.	N0196-106 	Spring-Clip SB-EF 20
Coilformer: EE 20/2k/K12/9-8/5.0-eg/A RV250 nat.	N0197-106 	
Solder-pin: z809/ua	73295-212	

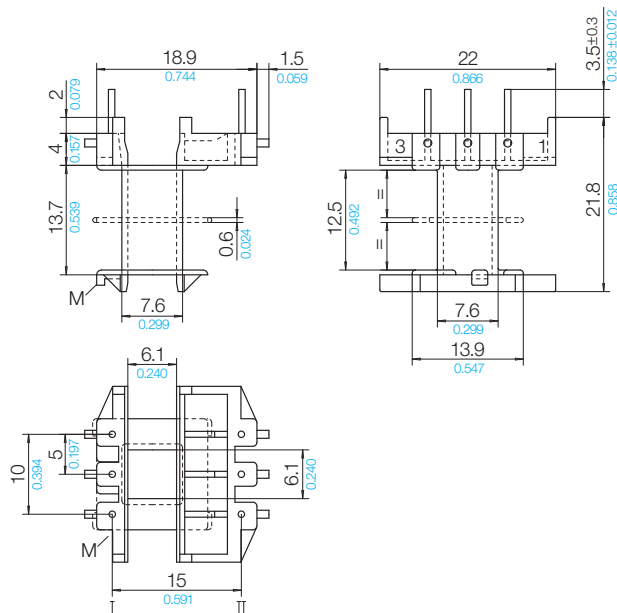

Grid View pin-side

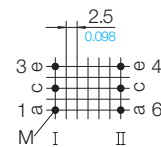

01 B 0 K

© 07/2018 by NORWE GmbH

Warranties:
refer to Terms and Conditions of Sale

NORWE GmbH

Postfach 13 56
51691 Bergneustadt
Paulstraße 5, Pernze
51702 Bergneustadt

Deutschland

Telefon +49 (0) 27 63-807-0
Telefax +49 (0) 27 63-807-77
E-mail verkauf@norwe.de
Internet www.norwe.de
www.norwe.eu

NORWE Inc.

P.O. Box 25 11
North Canton, OH 44720-0511
United States of America
Telefon +1-330 497-8113
Telefax +1-330 305-0592
E-mail usa@norwe.com
Internet www.norwe.com



Valid version of
data sheet online

QR Online-Version