

EE 8 – EE 32 Horizontal

The coilformers are made in gfr Polyamide PA66 of type p6g (RTI long-range temperature +125° C), x2g5 (RTI long-range temperature +120° C) and A3X2G10, sw (RTI long-range temperature +115° C). Pin material is tin bronze, tinned for solder-pins and brass, tinned for solder-tags. Max. solder temperature +350° C, 2 sec. Special materials – e.g. irradiated cross-linked – and designs on request, dimensions in mm/inch.

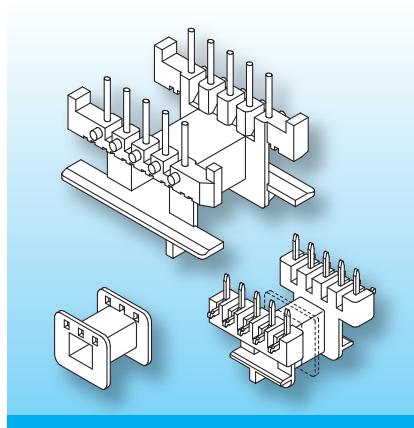

This group of horizontal coilformers is sorted by ferrite core / lamination size and each by pinning with straight pins, side-wrapping pins, solder-tags and conventional coilformers.

Most designs feature terminal strips with “noses” which provide tension-relief of the winding wires and “stand-offs” which allow clean soldering of the coilformer onto the pcb to minimize cold-solder joints. Some coilformers also feature extended flanges to prevent clips sliding off.

Type	Order-Code	Accessories
Coilformer: EE 12.6/1k/cc/p6g	09700-024	Spring-Clip SB-EF 12.6

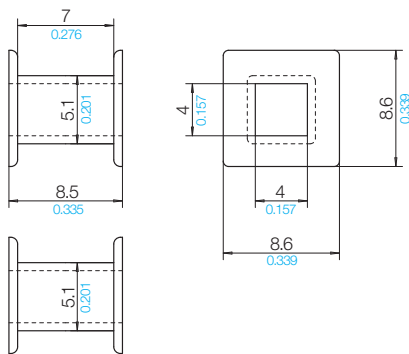

© 12/2011 by NORWE GmbH

All dimensions in mm/inch

The permissible deviations according to DIN 16901 apply as tolerances

Warranties: refer to Terms and Conditions of Sale

NORWE GmbH

Postfach 13 56
 51691 Bergneustadt
 Paulstraße 5, Pernze
 51702 Bergneustadt
 Deutschland
 Telefon +49 (0) 27 63-807-0
 Telefax +49 (0) 27 63-807-77
 E-mail verkauf@norwe.de
 Internet www.norwe.de
 www.norwe.eu

NORWE Inc.

P.O. Box 25 11
 North Canton, OH 44720-0511
 United States of America
 Telefon +1-330 497-8113
 Telefax +1-330 305-0592
 E-mail usa@norwe.com
 Internet www.norwe.com