

M 20 – M 55 Vertical

The coilformers are made in grf Polyamide PA66 of type p6g (RTI long-range temperature +125° C) and x2g5 (RTI long-range temperature +120° C). Pin material is tin bronze, tinned. Max. solder temperature +350° C, 2 sec. Special materials – e.g. irradiated cross-linked – and designs on request, dimensions in mm/inch.

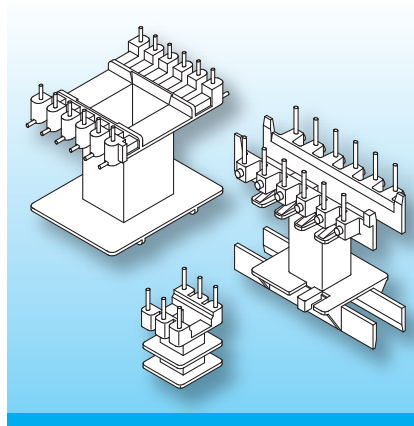

This group of vertical coilformers is sorted by ferrite core / lamination size and each by pinning with straight pins and side-wrapping pins. Most designs feature terminal strips with “noses” which provide tension-relief of the winding wires and “stand-offs” which allow clean soldering of the coilformer onto the pcb to minimize cold-solder joints. Some coilformers also feature extended flanges to prevent clips sliding off.

| Type | Order-Code | Accessories |
|--|------------------------|-------------|
| Coilformer: M 42/1k/a4-8/5.0-km/p6g Solder-pin: h813/ua | 01400-024 73499-212 | on request |

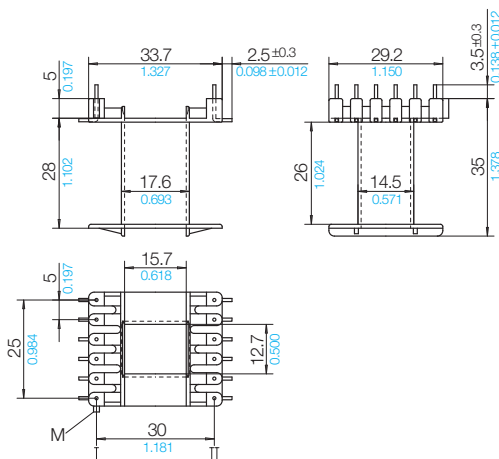

Grid
View pin-side

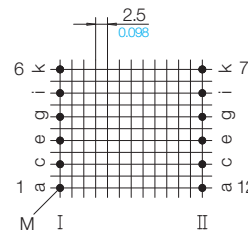

© 01/2012 by NORWE GmbH

All dimensions in mm/inch
The permissible deviations according to DIN 16901 apply as tolerances
Warranties:
refer to Terms and Conditions of Sale

NORWE GmbH

Postfach 13 56
51691 Bergneustadt
Paulstraße 5, Pernze
51702 Bergneustadt
Deutschland
Telefon +49 (0) 27 63-807-0
Telefax +49 (0) 27 63-807-77
E-mail verkauf@norwe.de
Internet www.norwe.de
www.norwe.eu

NORWE Inc.

P.O. Box 25 11
North Canton, OH 44720-0511
United States of America
Telefon +1-330 497-8113
Telefax +1-330 305-0592
E-mail usa@norwe.com
Internet www.norwe.com